

Ivoprop Corp.

2615 East. 67th Street Unit E
Long Beach, CA 90805
Tel. (562) 602-1451 Fax. (562) 602-1374
ivoprop@gmail.com www.ivoprop.com

QUICK ADJUSTMENT MAGNUM INSTRUCTIONS

PITCH CONTINUOUSLY ADJUSTABLE ON THE GROUND IN A MATTER OF SECONDS BY TURNING THE SCREW ADJUSTOR IN THE CENTER OF THE PROP.
THE PITCH RANGE IS FROM 6 TO 23 DEGREES ON THE TIP OF 76" PROP OR INCHES OF HELIX
ADVANCEMENT FROM 30" TO 90" ON REGULAR PITCH PROPS.

HOW IT WORKS

THE SUPERCAM IS WELDED ON THE END OF TORSIONAL ROD. EACH SUPERCAM PIN FITS INTO THE GROOVE IN THE SCREW ADJUSTOR. TURNING THE SCREW ADJUSTOR CAUSES EACH SUPERCAM TO ROTATE AND TURN THE TORSIONAL ROD AND THEREBY TWIST THE BLADE THEREFORE CHANGING THE PITCH.

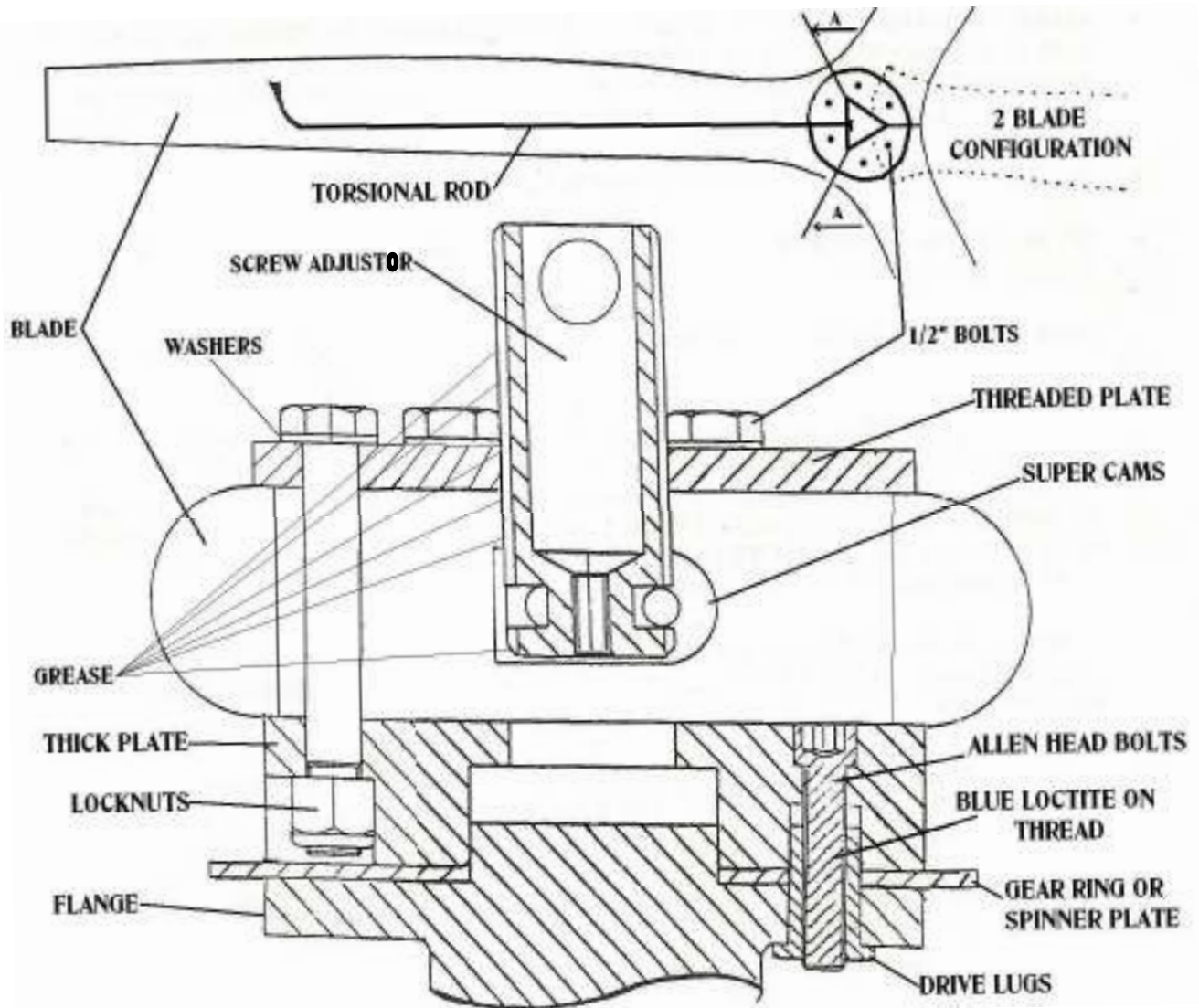

Ivoprop Corp.

2615 East. 67th Street Unit E
Long Beach, CA 90805
Tel. (562) 602-1451 Fax. (562) 602-1374

QUICK ADJUSTMENT MAGNUM INSTRUCTIONS ASSEMBLY

- MOUNT THE THICK PLATE ON THE FLANGE USE ALLEN HEAD BOLTS AND BLUE LOCTITE OR LOCKNUTS. TORQUE AS FOLLOWS **3/8" BOLTS TO 30 FT. X LBS. / 7/16" BOLTS TO 45 FT. X LBS. AND 1/2" BOLTS TO 65 FT. X LBS.**
- INSERT 1/2" BOLT WITH A WASHER THROUGH THE 1/2" THREADED PLATE.
- PIVOT THE BLADE SO THAT SUPERCAM PIN IS IN THE GROOVE OF THE SCREW ADJUSTOR.
- INSERT SECOND BOLT WITH THE WASHER.
- MOUNT THE BLADE WITH 1/2" PLATE LOOSELY ON THE THICK PLATE WITH 1/2" LOCKNUTS.
- INSERT REMAINING BLADES AND BOLTS.
- **TORQUE 1/2" BOLTS TO 65 FT. X LBS.**

- IT TAKES 6.5 TURNS OF THE SCREW ADJUSTOR EACH WAY (TOTAL 13 TURNS) TO GO THROUGH THE FULL PITCH RANGE.
- WIRE THE SCREW ADJUSTOR EITHER TO THE DRILLED HEAD BOLTS OR AROUND THE BLADE.
- MAINTAIN **65FT X LBS.** ON MOUNTING BOLTS.
- USE ONLY HARDWARE SUPPLIED WITH THE PROP. NEVER DRILL OR MODIFY THE BOLT HOLES.
- MAKE SURE THAT THERE IS AT LEAST 4" OF CLEARANCE BETWEEN THE BLADE TIPS AND TRAILING EDGE OF THE WING, RADIATOR, RUDDER, OR WHATEVER BECAUSE THE BLADES ARE DESIGNED TO FLEX BACK AND FORTH MORE THAN WOODEN BLADES.
- DO NOT CUT PROP ANY LESS THAN **58"** IN DIAMETER.
- DO NOT SLIDE YOUR FINGERS ALONG THE TRAILING OR LEADING EDGE OF THE BLADE. THE FIBERS MAY PIERCE YOUR SKIN.
- BEFORE TAKING PROP APART BRING THE SCREW ADJUSTOR TO NEUTRAL POSITION.
- THERE IS A FRICTION BETWEEN TORSIONAL ROD AND THE BLADE WHICH KEEPS THE SUPERCAM FROM COMING BACK TO ITS ORIGINAL NEUTRAL POSITION WHEN THE SCREW ADJUSTOR IS BROUGHT TO ITS ORIGINAL NEUTRAL POSITION. TO BRING IT BACK YOU NEED BREAK THE FRICTION AWAY BY EITHER TURNING SCREW ADJUSTOR ABOUT TWO TURNS THE OPPOSITE WAY OR GRABBING BLADES ON THE TIP BY HAND AND TWIST THEM BACK.
- IF YOU ARE GOING TO USE OTHER THAN SKULL CAP TYPE SPINNER MAKE SURE THAT THERE IS AT LEAST 1/4" CLEARANCE BETWEEN BLADES AND CUT-OUTS IN THE SPINNER.
- IF YOUR AIRCRAFT HOLDS U.S. EXPERIMENTAL AIR WORTHINESS CERTIFICATE YOU ARE SUPPOSED TO CONTACT THE FAA FSDO BEFORE FLYING THE AIRCRAFT. WHEN NOTIFIED, THE FAA INSPECTOR CAN DETERMINE IF THE PROCEDURE WAS A MAJOR CHANGE (AS DEFINED PER FAR 21.93 AND LISTED IN APPENDIX A TO PART 43) AND IF ANY ADDITIONAL INSPECTIONS OR OPERATING LIMITATIONS ARE NEEDED PRIOR TO FLIGHT.
- ENJOY FLYING WITH IVOPROP.